



ROSENFIRE

YOUR NEXT EQUIPMENT

TECHNICAL SHEET



UHPS 42/100 B18 RETROFIT

The fire engines for modules consist of self-priming piston pumps mounted on a welded steel frame protected against corrosion by epoxy paint. The hoses reels are made by die cast structure in light alloy with galvanized steel axial feed, retractable handle and locking system. Optionally is available electric rewinding system. The motor pump is complete with a full / mist jet gun. The motor pumps can be supplied with a traditional mixing system which allows a regular and pressure loss insensitive mixing regardless the length, the roughness and the diameter of the delivery pipe. The high-pressure system (100bar) allows a minimum consumption of the water reserve with an effective and pushed atomization. The motor pump is equipped with an automatic acceleration system which automatically accelerates the engine when the water/foam lance is opened and decelerates when the lance is closed. This system guarantees lower fuel consumption, safeguarding the environment, and the motor pump can be used by a single operator.



ENGINE

Make and type: B&S V-TWIN VANGUARD 18 HP
Cylinders: 2 – cast iron sleeve
Bore x Stroke: 72 x 70 mm.
Displacement: 570 cc.
Engine output: 13,43 kW / 18 HP-N(80/1269/CEE) ISO
Max Torque: 30,6 Nm @ 200 rpm
Fuel tank: 8,5 liters integrated
Oil capacity: 1,7 liters
Length: 318 mm.
Width: 410 mm
Height: 438 mm
Dry weight: 33 kg.



PUMP

Type: Gear pump with (3) high pressure plungers
Max output: 42 liters/min
Max pressure: 100 bar
Pump rpm: 1450 rpm
Absorbed power: 9,5 kW / 12,90 HP
Suction inlet: STORZ

FOAM SYSTEM

Type: «On-line» system
To admix directly the foam liquid on the outlet and to have the possibility to have water on the second outlet at the same time.





ROSENFIRE
YOUR NEXT EQUIPMENT

TECHNICAL SHEET



UHPS 42/100 B18 RETROFIT

MAIN HOSE REEL

High pressure main hose reel manufactured with high resistance light alloy, with locking system, manual rewinding and 80 meters HP hose type R1 with quick coupling. Swiveling system for hose orientation and hose guide. Supplied separately, complete with 3 metre hose for connection to the motor pump and not mounted on the frame.

«ALL IN ONE» TRIPLE USE GUN

Ergonomic gun with three commutating levels:

1. Full water jet
2. Nebulized water jet
3. Foam jet

Output: 25 lt / 1'

Range: 20 meters water full jet

The handle is disconnectable from nozzle and can be used with other accessories.

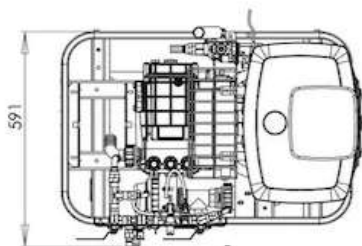
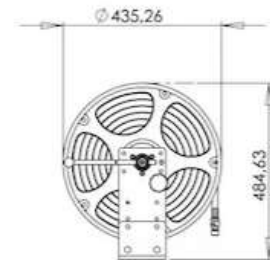
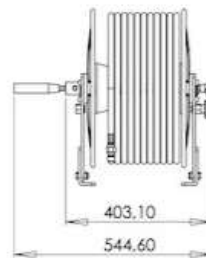
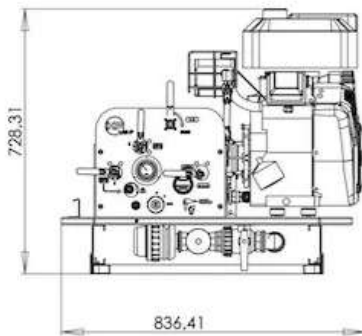

ACCESSORIES

- Suction hose, one piece, 6 meters of steel coiled rubber hose with STORZ coupling on one side and suction valve on the other side
- Suction key
- Small tool kit (engine original)
- Booklets for pump and engine use



ROSENFIRE S.r.l.
Via G. Bormioli, 3 - I-25135 BRESCIA / ITALY
Ph. +39 030 2548566 - Fax +39 030 2548420
Web www.rosenfire.it - Mail info@rosenfire.it





ROSENFIRE

YOUR NEXT EQUIPMENT

TECHNICAL SHEET



UHPS 42/100 B18 RETROFIT

DRAIN SYSTEM (Optional)

The compressor kit allows the quick emptying of the piston pump and all piping. The 12 V compressor is directly connected to the suction collector of the pump. Very useful and safe for climates with temperatures below 0° C.

HOSE REEL ELECTRICAL REWIND (Optional)

